

ICE® Model 92C Hydraulic Vibratory Driver/ Extractor with Model 800G Power Unit



- Highest frequency (1500 vpm) and centrifugal force (2300 kN) in its class.
- 597kW CAT C18 Tier 2 (Stage II) engine meets all EPA & EU emission regulations.
- Up to 1125 kN line pull for extraction.

Patented Dual-pull™ suppressor provides maximum vibration isolation during driving and light extraction combined with high pull capability for tough extraction jobs.

Optional bias weight up to 2495 kg increases pile penetration rates in difficult soils.

Maximum efficiency and reliability ensured by our open-loop hydraulic system. Highest quality, reliable piston pumps and motors.

Remote-control pendant for vibrator and clamp with emergency stop. Engine speed control for fuel efficiency.

Full range of clamps available for sheet piling, H-Beams, pipe & caissons.

Adaptable for underwater, low headroom or box leads operation.

Heavy steel enclosure and fuel-tank subbase protect power unit.

Designed and manufactured in the USA by ICE®, world leader in cost-effective foundation equipment since 1974.



ICE® Model 92C

Hydraulic Vibratory Driver/ Extractor with Model 800G Power Unit



Dimensions

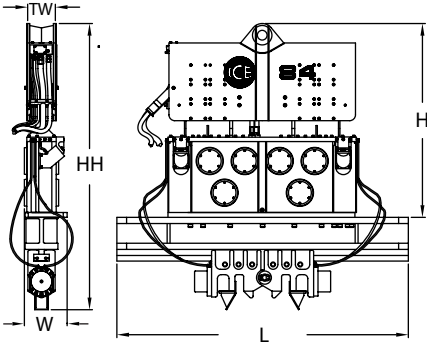

Clamps & Accessories

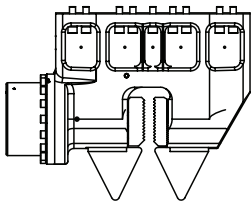

Model 385 Sheeting Clamp

Clamping force
385 tons, 3425 kN
Weight
5,400 lbs, 2455 kg

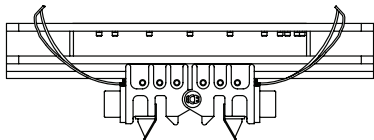

10' Caisson Beam with Model 142BH Caisson Clamps

Clamping force
284 tons, 2520 kN
Weight
10,242 lbs, 4546 kg

Other Model 92C Accessories

Low-headroom suppressor
Wireless Remote
Bias weights
Vibrator stand
Sled for 32" leads

Model 92C Vibrator Specifications

Eccentric moment	94 kg-m
Maximum frequency	1500 vpm
Centrifugal force	2300 kN
Amplitude (free w/o clamp)	37 mm
Standard line pull for extracting	850 kN
Maximum line pull for extracting	1125 kN
Weight (no clamp or hoses)	7240 kg
Non-vibrating weight	2070 kg
Height without clamp (H)	2550 mm
Length (L)	2485 mm
Width (W)	530 mm
Throat width (TW)	362 mm
Hydraulic hose length	46 m
Hydraulic hose weight	1090 kg
Height with sheeting clamp* (HH)	3720 mm
Weight with sheeting clamp & 1/2 hoses*	10230 kg
Height with beam & caisson clamps* (HH)	3203 mm
Weight with beam & caisson clamps*	12440 kg

* See "Clamps and Accessories Manual" for in-depth description

Model 800G Power Unit Specifications

Engine	CAT C18
Power	597 kW
Operating speed	1800 rpm
Maximum motors pressure	380 bar
Motors flow (no load)	845 lpm
Clamp pressure	310 bar
Clamp flow	21 lpm
Weight (w/ full fluid & 1/2 fuel)	12020 kg
Length	5540 mm
Width	2035 mm
Height	2630 mm
Hydraulic reservoir	2080 liters
Fuel capacity	750 liters

International Construction Equipment, Inc.
301 Warehouse Drive
Matthews, NC 28104 USA
888-ICE-USA1 / 704-821-8200
sales@iceusa.com / www.iceusa.com

Constant improvement and engineering progress make it necessary that ICE®, Inc. reserve the right to make specification changes without notice. Please consult ICE® for the latest available information.

©International Construction Equipment, Inc. All rights reserved. January 2013.