

ICE[®] MODEL D-50

SINGLE-ACTING DIESEL PILE HAMMER



Simple, reliable design
Automatic lubrication
Optional variable fuel control
Optional hydraulic trip

Equipped with ICE[®] Box leads guides
Uses standard ICE[®] drive caps
Swinging, fixed and sliding leads available
Spotters available for precise pile positioning

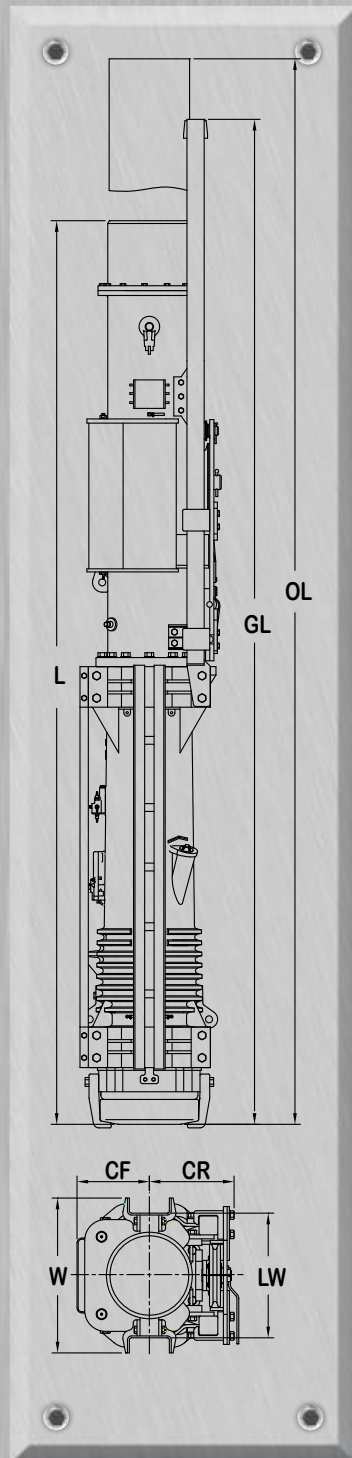

Working Specifications

Ram weight	11,355	lbs	5 150	kg
Rated energy (fuel setting 4)	134,100	ft-lbs	181 800	Nm
Stroke at rated energy (fuel setting 4)	11.81	feet	3 600	mm
Energy at fuel setting 3	119,200	ft-lbs	161 600	Nm
Energy at fuel setting 2	108,025	ft-lbs	146 460	Nm
Energy at fuel setting 1	96,850	ft-lbs	131 300	Nm
Energy at maximum stroke	161,800	ft-lbs	219 400	Nm
Maximum geometric stroke	14.25	feet	4 345	mm
Blows per minute	35-52			

Weights

Bare hammer with trip	25,420	lbs	11 530	kg
Hammer with box lead guides	27,700	lbs	12 550	kg
Drive cap base	DCB-2HD			
Drive cap base weight	1,670	lbs	758	kg
Striker plate	845	lbs	383	kg
Cushion material	134	lbs	61	kg
Pile insert	DCC-16			
Pile insert weight	1,260	lbs	572	kg
Operating weight with drive cap above	31,609	lbs	14 324	kg

Capacities

Fuel tank	23.2	gal	88	l
Lube oil tank	4.5	gal	17	l

Dimensions

Hammer length (L)	18.3	ft	5 560	mm
Length with trip guides (GL)	23.4	ft	7 130	mm
Length at max stroke (OL)	24.8	ft	7 525	mm
Overall width (W)	37.6	in	954	mm
Standard box leads width (LW)	32	in	813	mm
Overall depth (CR + CF)	44.3	in	1 124	mm
Centerline to rear (CR)	25.4	in	645	mm
Centerline to front (CF)	18.9	in	480	mm

DH-D50-Mar 2012

INTERNATIONAL CONSTRUCTION EQUIPMENT, INC.

Corporate offices: 301 Warehouse Drive, Matthews, NC USA
Phones: 888 ICEUSA1, 704 821-8200

info@iceusa.com
www.iceusa.com