

ICE® Model 50ZR Zero-Resonance™ Hydraulic Vibratory Driver/ Extractor with Model 595GZ Power Unit



WWW.ICEUSA.COM
888-ICE-USA1

Variable moment – zero to 4400 in-lbs (51 kg-m)
High centrifugal force for maximum pile penetration rates
Up to 120 tons (1070 kN) line pull for extraction



ICE Model 50ZR Zero-Resonance™ Pile Hammer

Eccentric moment	4400 in-lbs	51 kg-m
Maximum Frequency	1650 vpm	
Driving Force	178 tons	1580 kN
Centrifugal force	170 tons	1510 kN
Amplitude (free w/o clamp)	0.85 in	22 mm
Standard line pull for extracting	120 tons	1070 kN
Weight (no clamp or hoses)	15,260 lbs	6922 kg
Non-vibrating Weight	4960 lbs	2250 kg
Height without clamp (H)	80 in	2032 mm
Length (L)	131 in	3330 mm
Width (W)	31 in	787 mm
Throat width (TW)	17.25 in	438 mm
Hydraulic hose length	150 ft	45 m
Hydraulic hose weight	1680 lbs	765 kg
Height with sheeting clamp (HH)	120 in	3025 mm
Weight with sheeting clamp & 1/2 hoses	18,800 lbs	8528 kg
Weight with beam, caisson clamps & 1/2 hoses	20,590 lbs	9340 kg

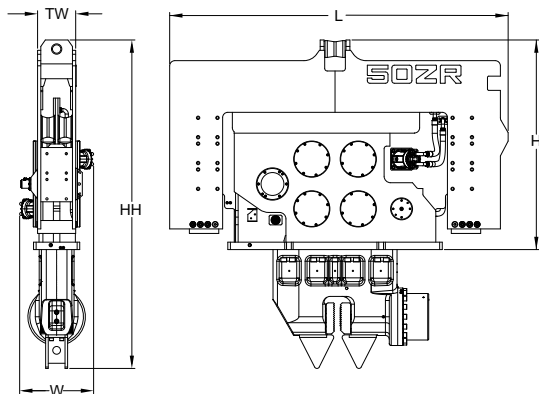

ICE Model 595GZ Power Unit

Engine	Caterpillar C15	
EPA/EU Emissions rating	Tier 3	Stage IIIA
Power	595 HP	444 kW
Operating speed	1800 rpm	1800 rpm
Maximum motors pressure	5500 psi	380 bar
Motors flow (no load)	160 gpm	610 lpm
Clamp pressure	4500 psi	310 bar
Clamp flow	6 gpm	20 lpm
Weight (w/ full fluid & 1/2 fuel)	16350 lbs	7420 kg
Length	160 in	4040 mm
Width	73 in	1855 mm
Height	100 in	2540 mm
Hydraulic oil capacity	430 gal	1630 liters
Fuel Capacity	150 gal	570 liters



Designed and manufactured in USA by ICE®
World leader in cost-effective foundation equipment since 1974.

Constant improvement and engineering progress make it necessary that ICE®, Inc reserve the right to make specification changes without notice.
Please consult ICE® for the latest available information.

ICE® Model 50ZR Zero-Resonance™ Hydraulic Vibratory Driver/ Extractor with Model 595GZ Power Unit



WWW.ICEUSA.COM
888-ICE-USA1

Variable moment allows zero eccentric moment at start-up and shut-down to eliminate disturbance to soil, structures and crane.

595 HP (444 kW) CAT C15 meets Tier 3 (Stage IIIA) EPA & EU emission regulations.

Optional 1700 kg of bias weight increases pile penetration rates in difficult soils.

Full range of clamps available for sheet piling, H-Beams, pipe & caissons and timber & concrete piles.

Maximum efficiency and reliability ensured by our open-loop hydraulic system. Highest quality, reliable piston pumps and motors.

Remote-control pendant for vibrator and clamp with emergency stop. Engine speed control for fuel efficiency.

Adaptable for underwater, low headroom or box leads operation.

Environmentally-friendly, non-toxic, biodegradable hydraulic oil.



Clamps & Accessories

ICE Model 140C Sheeting Clamp		
Clampng Force	140 tons	1245 kN
Weight	2200 lbs	1000 kg

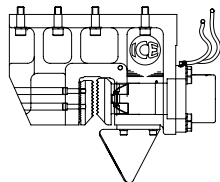

ICE 6.5' HD Beam & 2 Model 145 Clamps		
Clampng Force	284 tons	2520 kN
Weight	6115 lbs	2775 kg

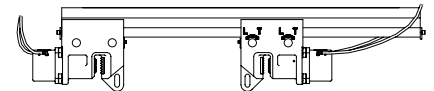

Model 50ZR Accessories

- 10' Clamp Extension
- 90° Turning Plate
- Bias Weights
- Vibratory Stand
- Wireless Remote



Designed and manufactured in USA by ICE®
World leader in cost-effective foundation equipment since 1974.