

# ICE® Model 77C Hydraulic Vibratory Driver/ Extractor with Model 800T Power Unit



WWW.ICEUSA.COM  
888-ICE-USA1

Design combines large eccentric moment (7,700 in-lbs, 88 kg-m) and high frequency for maximum driving performance. 800 HP (597 kW) CAT C18 meets EPA Tier 4/EU Stage IV engine emission regulations  
Up to 95 tons (845 kN) line pull for extraction.



ICE Model 77C Vibratory Pile Hammer		
Eccentric moment	6600 in-lbs	76 kg-m
Maximum frequency	1600 vpm	
Driving Force	310 tons	2885 kN
Centrifugal force	300 tons	2650 kN
Amplitude (free w/o clamp)	1.4 in	35 mm
Standard line pull for extracting	95 tons	850 kN
Maximum line pull for extracting	125 tons	1125 kN
Weight (no clamp or hoses)	15860 lbs	7195 kg
Non-vibrating Weight	4560 lbs	2070 kg
Height without clamp (H)	101 in	2550 mm
Length (L)	98 in	2485 mm
Width (W)	21 in	530 mm
Throat width (TW)	14.25 in	362 mm
Hydraulic hose length	150 ft	46 m
Hydraulic hose weight	2400 lbs	1090 kg
Height with sheeting clamp (HH)	147 in	3720 mm
Weight with sheeting clamp & 1/2 hoses	22910 lbs	10390 kg
Height with beam & caisson clamps	153 in	3880 mm
Weight with beam, caisson clamps & 1/2 hoses	27300 lbs	12285 kg

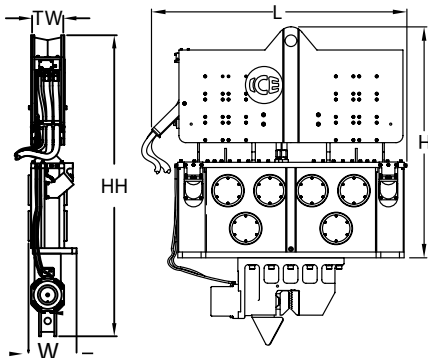

ICE Model 800T Power Unit		
Engine	Caterpillar C18	
EPA/EU Emissions rating	Tier 4	Stage IV
Power	800 HP	597 kW
Operating speed	1800 rpm	1800 rpm
Maximum motors pressure	5200 psi	345 bar
Motors flow (no load)	235 gpm	900 lpm
Clamp pressure	4500 psi	310 bar
Clamp flow	6 gpm	20 lpm
Weight (w/ full fluid & 1/2 fuel)	26500 lbs	12020 kg
Length	250 in	6350 mm
Width	83 in	2110 mm
Height	104 in	2630 mm
Hydraulic oil capacity	550 gal	2080 liters
Fuel Capacity	215 gal	800 liters



DESIGNED AND MANUFACTURED IN USA BY ICE®

WORLD LEADER IN COST-EFFECTIVE FOUNDATION EQUIPMENT SINCE 1974.

Constant improvement and engineering progress make it necessary that ICE®, Inc reserve the right to make specification changes without notice. Please consult ICE® for the latest available information.